

# Particle Filter Penetration Test System following the EU Standard EN 13274-7



## PFP2020 System

TSE Systems has created a new economical and easy to use system reflecting current needs for filter testing based on our years of experience building turn-key systems for inhalation toxicology. We have taken our knowledge of aerosol generation, exposure chambers, and sampling equipment to create this system. The system is used for testing particle filter penetration for respiratory protective devices and follows the European Standard EN 13274-7.

## System Principle

An aerosol of paraffin oil droplets or optionally of sodium chloride particles is generated by an aerosol generator. The test aerosol is fed into the test chamber, passing through the fixed test filter at a given flow rate utilizing a vacuum pump. If the flow rate from the generator is not high enough, an additional supply of air can enter the system via a HEPA filter before the test chamber to ensure a homogeneous aerosol concentration within the test chamber. The particle concentration of the aerosol is measured immediately before and after the filter under test using a spectrometer.

## PFP2020 Equipment

The apparatus is shown schematically and can be extended to confirm with other filter test standards.

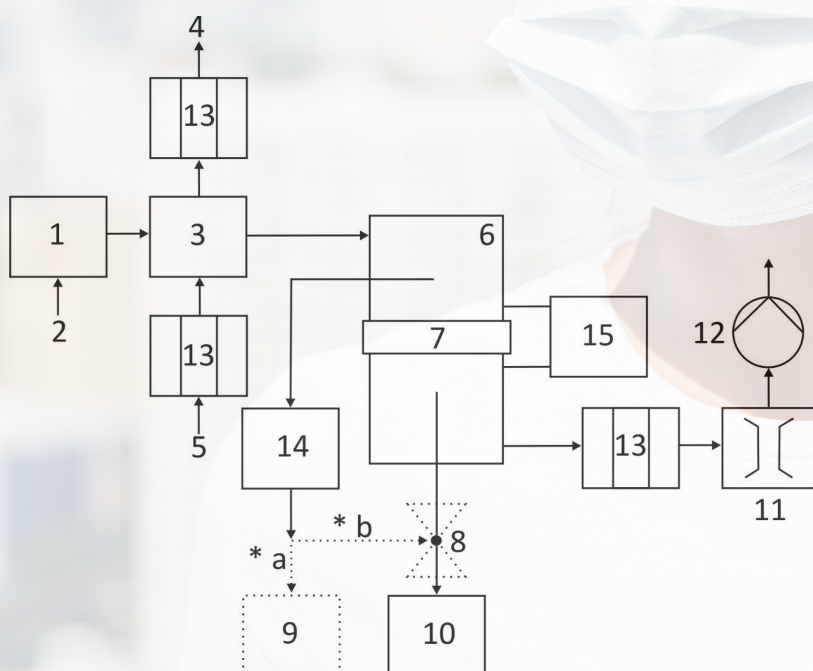

## Features

- Inlet and exhaust air are HEPA filtered
- Flow control via a precision mass flow controller
- Monitoring of the pressure across the test filter
- Unique sample holding design for flat filter / textile membranes
- Aerosol concentration is measured immediately before and after the particle filtering device by real-time spectrometers

## Key

1. Paraffin oil aerosol generator
  2. Compressed air supply / air conditioning
  3. Flow control module
  4. Air outlet (test flow less than the output of the generator)
  5. Dilution air (test flow greater than the output of the generator)
  6. Filter test chamber
  7. Test filter membrane
  8. Two-way sample selection valve
  9. Second aerosol spectrometer (optional)
  10. Aerosol spectrometer
  11. Mass flow controller
  12. Suction pump
  13. Particle / active carbon filter
  14. Aerosol dilution unit
  15. Differential pressure sensor
- \*a or \*b configuration as option

## Options / Supplementary Equipment

- Compressed air
- Depending on the configuration needed a two-way sample selection valve and / or a second aerosol spectrometer
- Fully automatic software control, via the DACO software program, including data logging for future statistical analysis
- Upgradable for NaCl testing
- Adapter for testing rigid filters and entire masks
- Upgradeable for filter testing according to ASTM F2299 or EN 143

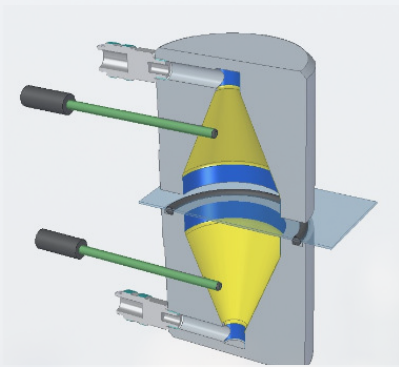

Internal configuration of the test chamber



Aerosol spectrometer including dilution unit

## Technical Specifications

Compressed air supply:	5 - 6 bar
Aerosol substances:	Paraffin oil, mainly < 1 µm
Air flow rate:	2...100 l/min
Aerosol spectrometer:	0.253 to 35.15 µm, model 11-D from Grimm 9 dust mass fractions: TSP, PM10, PM4, PM2.5, PM1, PMcoarse
Aerosol dilution unit:	1:10, sample flow 1.2 l/min

## About us

**TSE Systems** is one of the leading manufacturers of high-quality research instruments with a global presence; we have committed ourselves to scientific innovation, reliability, quality, and excellent support. Our team of engineers, biologists, and physiologists are continually researching ways to upgrade our systems and create new products to meet the current scientific demands.

TSE Systems GmbH \*  
 Louisenstr. 65, 61348 Bad Homburg, Germany

\* a member of the TSE Systems International Group

www.TSE-Systems.com  
 info@TSE-Systems.com

Contact our distributor

**Animalab**

www.animalab.eu  
 info@animalab.eu